

# Low Cost, Single Inductor Non-Isolated AC/DC LED Driver Design using TPS92314A

Abhijeet Godbole, Bharat Agrawal, TM Leung

Lighting Power Products

## ABSTRACT

The control principle of the TPS92310/11/12/14 is to provide constant current line and load regulation for primary-side sensing flyback configurations operating in critical conduction mode (CRM), removing the opto-coupler used for secondary-side feedback.

The new application circuit uses a single inductor rather than a bulky transformer, saving board space and BOM cost while still meeting the standard performance specifications of an LED driver.

This application report describes how to design a non-isolated AC/DC buck LED driver with an integrated PFC control using the TPS92314A from Texas Instruments. This application report includes schematics, switch node waveforms and test results to help the user better understand how to retain a very tight line and load regulation when applying the IC as a buck regulator with the help of external add-on circuitry that modifies the control equation of the TPS92314A. In this way, tighter line and load regulation specifications required by certain applications can be met.

## Contents

1	Design Specifications:.....	1
2	Application Schematic: Single Inductor, Non-Isolated AC/DC LED Bulb Design.....	2
3	Principles of Operation .....	2
4	Experimental Results and Performance Characteristics.....	3
4.1	Switch Node Waveform at VAC = 110V .....	3
4.2	Switch Node Waveform at VAC = 220V .....	4
4.3	Output Current Variation with Respect to Input Voltage.....	5
4.4	Power Factor Variation with Respect to Input Voltage.....	5
4.5	Detailed Test Results for 7W Design .....	6
5	External Add On Circuit to Meet Tighter Line and Load Regulation Specification .....	6
6	Conclusion .....	8
7	References .....	8

## 1 Design Specifications:

**Table 1. Design Specifications**

<b>Input Voltage Range (Vin)</b>	<b>Universal, 90V-276V AC RMS</b>
<b>Output Voltage (Vout)</b>	<b>29V</b>
<b>Load Current (Iout)</b>	<b>230mA</b>
<b>Power Factor</b>	<b>Greater than 0.9 in Vin range</b>
<b>Current Total Harmonic Distortion (ITHD)</b>	<b>Less than 25% at 220V AC RMS</b>
<b>Output Short Circuit Protection</b>	<b>Yes</b>
<b>Output Open Circuit Protection</b>	<b>Yes</b>

## 2 Application Schematic: Single Inductor, Non-Isolated AC/DC LED Bulb Design

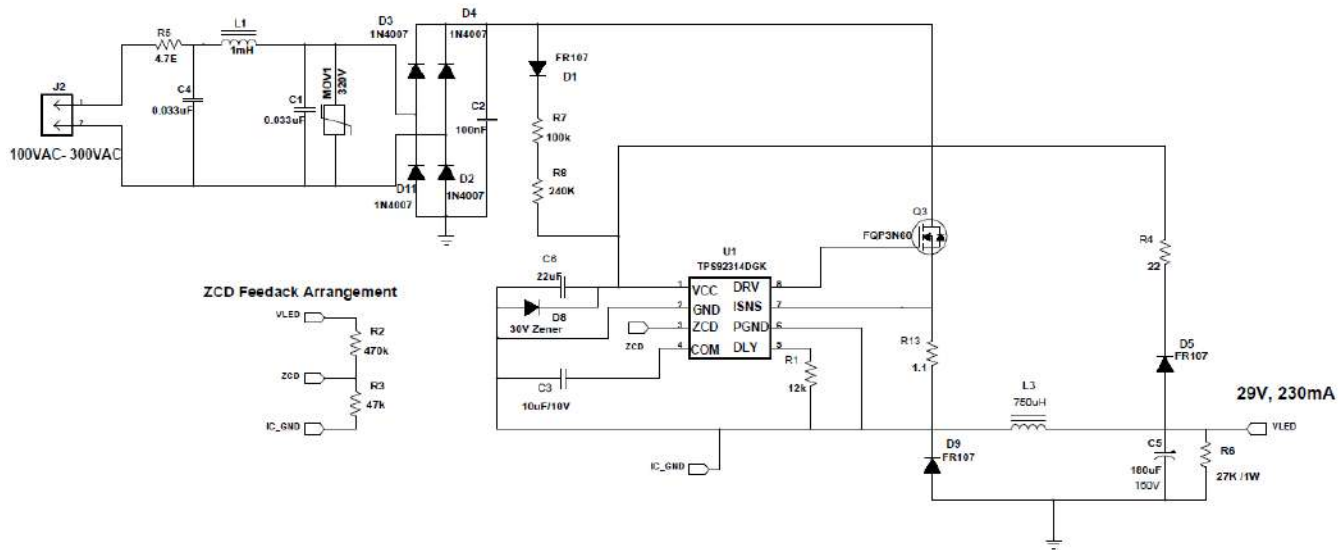

Figure 1. TPS92314 based non isolated, single inductor LED driver for 7W application

## 3 Principles of Operation

The TPS92314A is an off-line AC/DC controller specifically designed to drive high power LEDs for lighting applications. With advanced features such as constant on-time control (for high Power Factor at input) and quasi-resonant switching (for high efficiency and reduced EMI signature), this controller can be used as a high-side switching buck controller to regulate the amount of energy being stored in the inductor. The need for an auxiliary winding, required in non-isolated designs to provide a DC supply to a controller, is eliminated with the use of energy from an output capacitor through a forward diode. This makes a small solution size, low cost and high efficiency possible, some of the key requirements for a residential bulb design.

See Figure 1 for a reference schematic describing key components in this buck design. The input AC voltage is rectified using a full bridge rectifier to obtain a unidirectional AC bus. This rectified voltage follows the AC input sine wave, due to the presence of a small 100nF input capacitor after the bridge required to obtain a high Power Factor. This rectified AC is connected to a drain of the High-Side switching MOSFET Q3, whose source is connected to the freewheeling diode D8 and inductor L3 to output capacitor C5. The TPS92314A switcher (U1) is referenced to switching node SW (which is IC\_GND in Figure 1).

The TPS92314 will not turn on unless the rectified input AC voltage is greater than the LED forward voltage, and there is no current drawn from the input source. This conduction time delay can be given by:

$$\Delta T = \text{Sine(Inverse)} \frac{V_{LED}}{\sqrt{2} \times V_{ac}} \quad (1)$$

As the TPS92314 operates in critical conduction mode, the inductor peak current is twice the input peak current. The desired value of inductance can be calculated as per the following equation:

$$L = \frac{[1.41 \times V_{AC} - V_{LED}] \times T_{on}}{\Delta I_{PEAK}} \quad (2)$$

Since the TPS92314A implements a critical conduction mode, the next ON cycle initiates only after the inductor current ramps down to zero. VLED voltage is fed back as supply to the TPS92314 through the diode and current limiting resistor (D5 and R4), because VLED is referenced to the input bridge ground. This enables the use of a single inductor and eliminates the need for bias winding. The use of a single inductor reduces overall system cost and solution size, but matches the necessary performance specifications listed in the next section.

In comparing fly-back and buck convertor current waveforms, fly-back output current is observed at tOFF time only due to the flyback action of the transformer. In buck convertor, the output current is observed during tON + tOFF time. For waveforms for both topologies, the tOFF time inductor current is the same at CRM operation. Thus after blanking time, the inductor current at ON time tON in both flyback and buck convertor will be at the same level.

A modified, non-isolated buck LED driver with the TPS92314 controller is as follows:

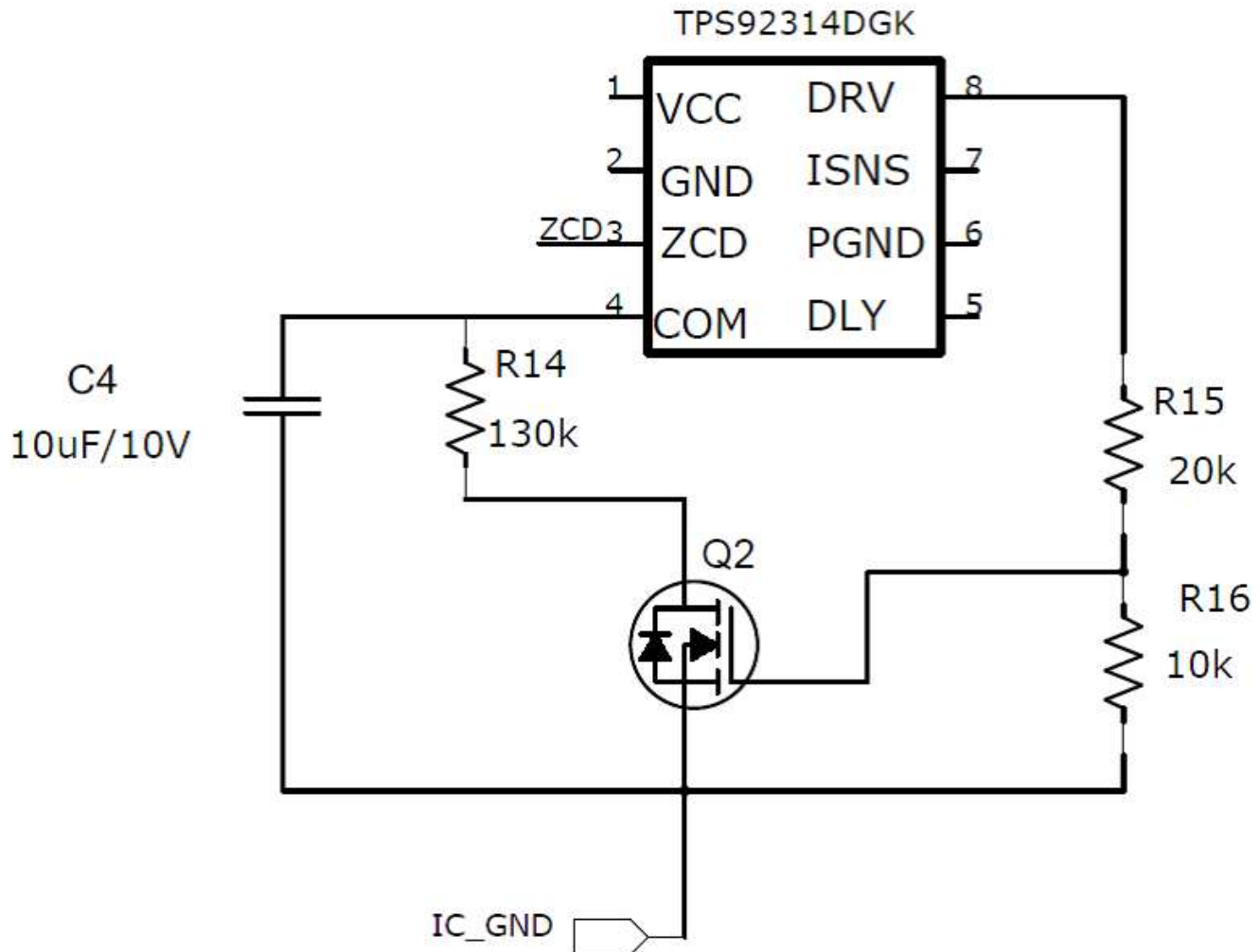

Figure 10. External Add On Circuit to meet Tighter Line and Load Regulation Specifications

This implementation meets tighter line and load regulation specifications for a non-isolated buck application with the TPS92314 controller by drawing the internal reference current when the gate driver is turned on (TON time) through small signal MOSFET Q2. The blanking timer appears to blank the input current at TON time in CRM buck operation. The user can meet the line regulation specifications by modifying the discharge current through small signal MOSFET Q2. Theoretically, if the discharge current is same as the compensation pin internal reference current (27uA), a controller output current can be controlled with the same level.

In Figure 10, the COMP voltage VCOMP is dependent on the TON time and is nearly constant in close loop operation. MOSFET Q2 is driven through the resistor divider from the gate drive pin (pin 8 of TPS92314) R15 and R16. The value of resistor R14 can be calculated as:

$$\frac{(V_{COMP} - V_{DS(ON)Q2})}{R14} = 27\mu A \quad (3)$$